

Description

The following paragraphs name and explain all components of the VP75 to give you an exact overview. The terms are used consistently throughout this manual and will help you identifying any part you may wish to find or order as a spare part.

Functional principle

The VP75 Additive Manufacturing System uses the **Fused Filament Fabrication (FFF)** process to build up workpieces in subsequent layers of 0.10 to 0.80mm thickness. The plastic filament is heated in the nozzle to its melting temperature and continuously conveyed by a cogwheel. The molten plastic is pressed through the bore of the nozzle tip and onto the heated print bed. After each layer the print bed is lowered by the preset layer height and the next layer is applied. The heat of the newly applied plastic ensures an adequate binding of the layers.

All temperatures and movement commands are provided by the GCODE, a file format previously generated with a “slicing” software. This file contains all information for a single print job and is uploaded to the 3D Printer via the [web interface](#). All Kühling&Kühling 3D Printers are built to operate best with [Slic3r](#), an OpenSource Software designed for professional 3D printing.

After the workpiece has been finished the user can leave it in the heated build chamber to slowly cool down thus reducing shrinkage and internal tensions, or he can immediately remove it and start the next print job. The layered building process enables the user to create even complex forms that otherwise could not be realized.

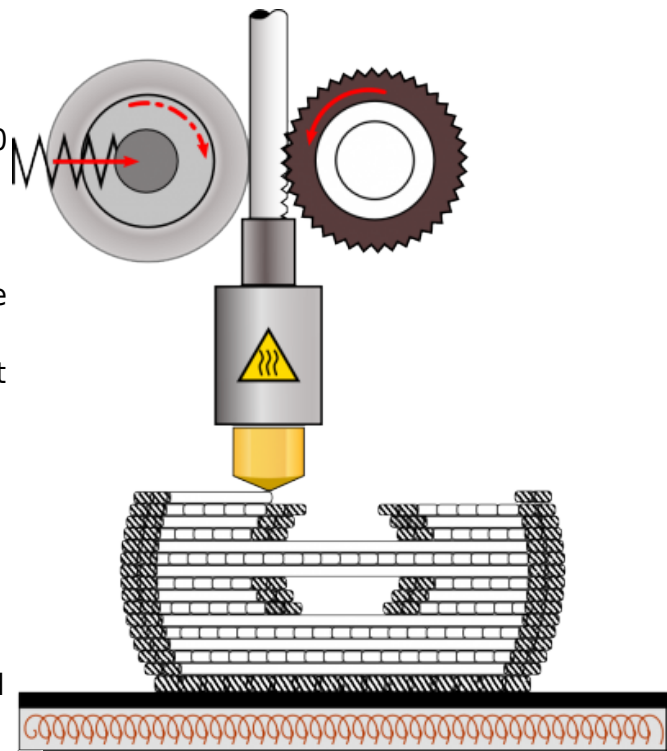

The layer-by-layer build-up of complex geometries becomes possible with FFF additive manufacturing machines.

Hardware components

No.	Description
1	Build chamber
2	Filament drawer
3	Touchscreen

The VP75 is built from a powder coated sheet-metal frame, covered with acrylic panels on the front. Its main functional sections are the upper [build chamber](#) and the lower [filament drawer](#). The build chamber is providing insight through its translucent door during production. It contains all mechanical components. At the rear side, the [connections](#) for ethernet, compressed air and mains supply can be found.

The [touchscreen](#) for operation is mounted at the front.

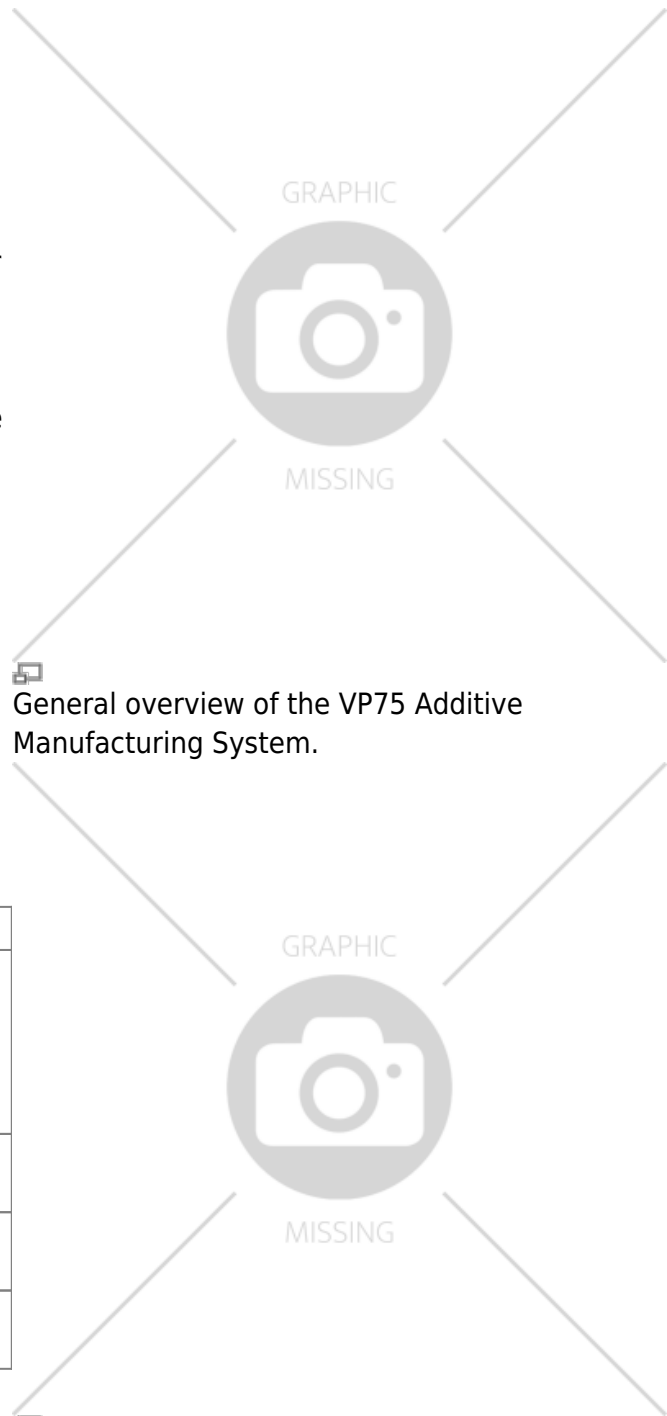

 General overview of the VP75 Additive Manufacturing System.

All references concerning directions are defined throughout this manual as follows:

Tag	Aspect	Description
F	Front	Standing in front of the machine's touchscreen and looking inside the build chamber. This is the reference view for all other directions.
L	Left	Left side of the machine, referred to the frontal view.
R	Right	Right side of the machine, referred to the frontal view.
B	Back	Backside of the machine, referred to the frontal view

All movement directions of the axes are defined throughout this manual as follows:

Tag	Called	Movement direction
X⊕	X positive	Print head moves to the right.
X⊖	X negative	Print head moves to the left.
Y⊕	Y positive	Print head moves backwards.
Y⊖	Y negative	Print head moves forward.
Z⊕	Z positive	Print head moves up.
Z⊖	Z negative	Print head moves down.

 Directions and aspects of the machine. All statements refer to the frontal view.

All movements of the extruder drives are defined throughout this manual as follows:

Tag	Called	Movement direction
⊕	extrude	clockwise rotation
⊖	retract	counter-clockwise rotation



Build chamber

No.	Description
1	Print Bed Unit
2	Chamber Heater Unit
3	Axes Gantry
4	Print Head Unit
5	Linear Axis

The build chamber is the main production area with the vertically moving [print table](#) and the two-directional horizontally moving extruder head inside.

All [electrical motors](#) are installed at their working point and equipped with a water cooling system. The [extruder head](#) moves on an H-frame, tooth-belt-driven by two separate stepper motors in X- and Y-direction. The [print table](#) is lifted and lowered in Z-direction by a spindle drive.

For regulating the temperature inside the build chamber two heating resistors in separate housings heat the air which then is circulated through the chamber by the fans.

Cables and hoses are installed in and guided by cable carriers.

To minimize air pollution from dissolved substances, an additional fan circulates the air through a filter element filled with granules of activated carbon.

The access to the build chamber is the

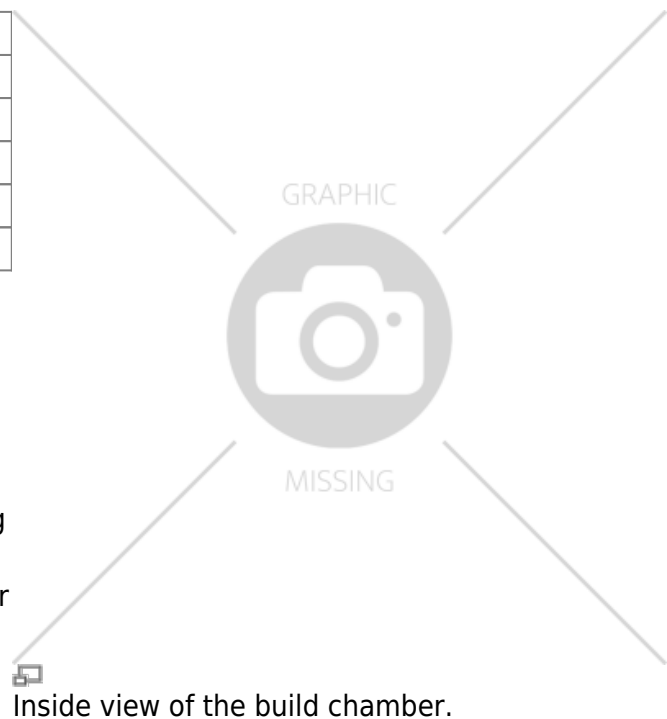

magnetically closed double door at the front.